





Инструкция по установке

MAZDA CX-5

(2011-)



Арт.: F.3811.003

 $D \text{ (kN)} = \frac{\text{MAX kg} \times X}{\text{MAX kg} + \text{MAX kg}} \times 0,00981$ 	 <p>2000 kg</p>	 <p>75 kg</p>	<p>D = 10,1 kN</p>
<p>MAZDA CX-5 (2011 - 2017; 2017-)  <input checked="" type="checkbox"/></p>			

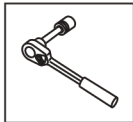

Вкрутить/выкрутить используя инструмент

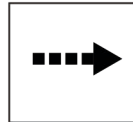

Движение



Поворот



Вкрутить/выкрутить не затягивая

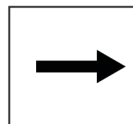





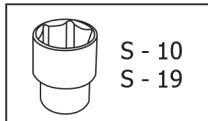
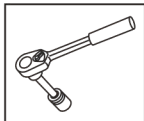



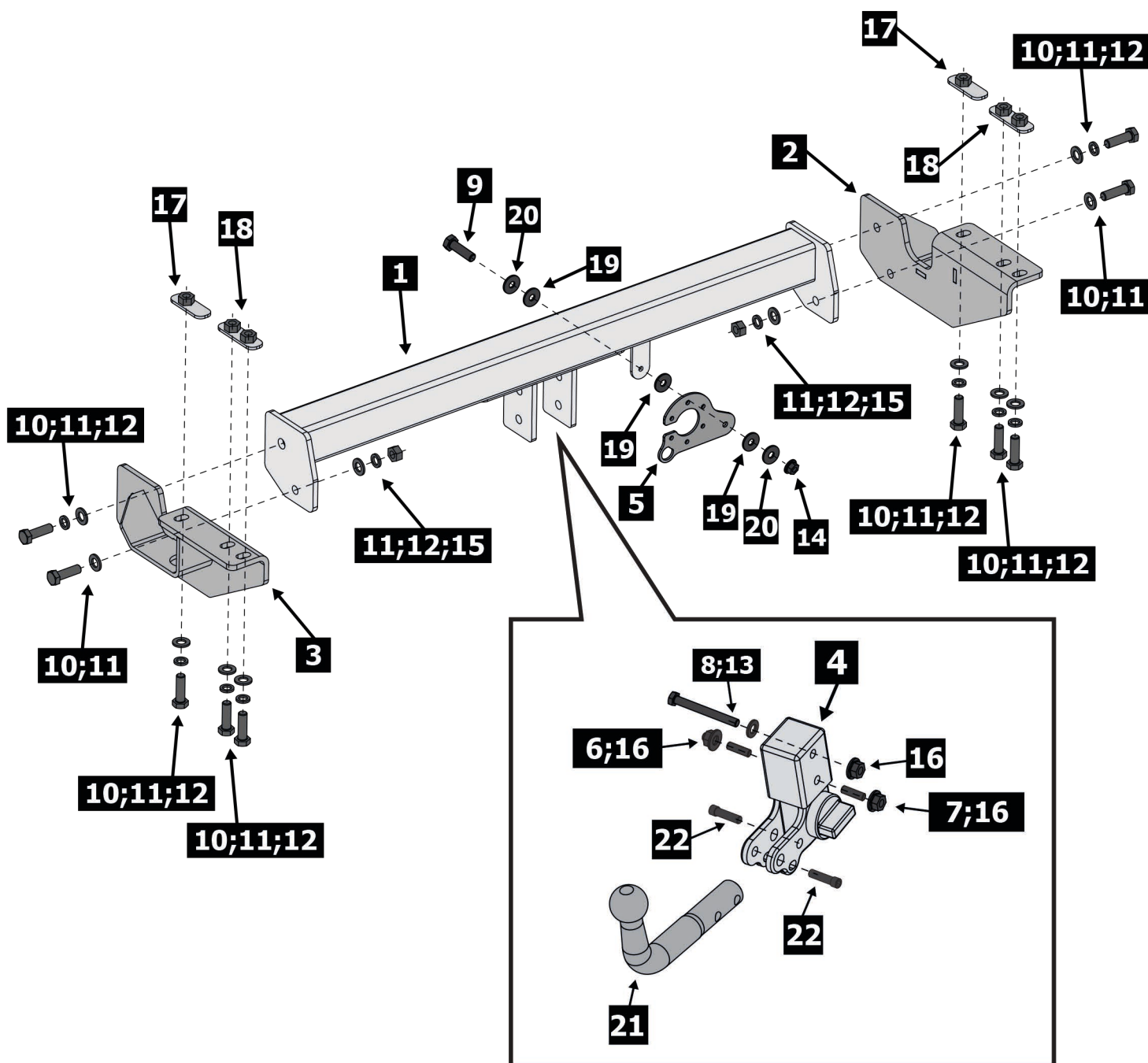

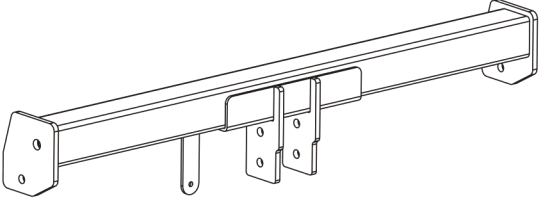
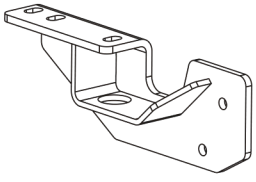
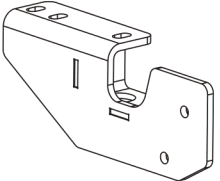
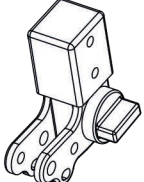

Расположение

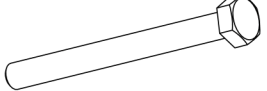

Используемый инструмент:



S - 10
S - 19

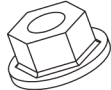
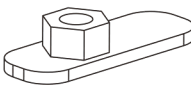
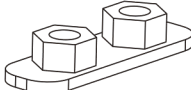

1	x1	Балка	
2	x1	Кронштейн левый	
3	x1	Кронштейн правый	
4	x1	Быстросъем	
5	x1	Подрозетник	
6	x1	Шпилька M12x35	
7	x1	Шпилька M12x35	
8	x1	M12x100	
9	x1	M6x25	
10	x10	M12x1.25x40	
11	x12	Ø 12	
12	x10	Ø 12	
13	x1	Ø 12	
14	x1	M6	
15	x2	M12x1.25	

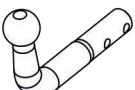
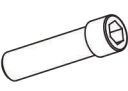
16	x3	M12	
17	x2	Закладная пластина	
18	x2	Закладная пластина	
19	x3	Ø 6 (полиамид)	
20	x2	Ø 6	
21	x1	Крюк	
22	x2	M12x45	

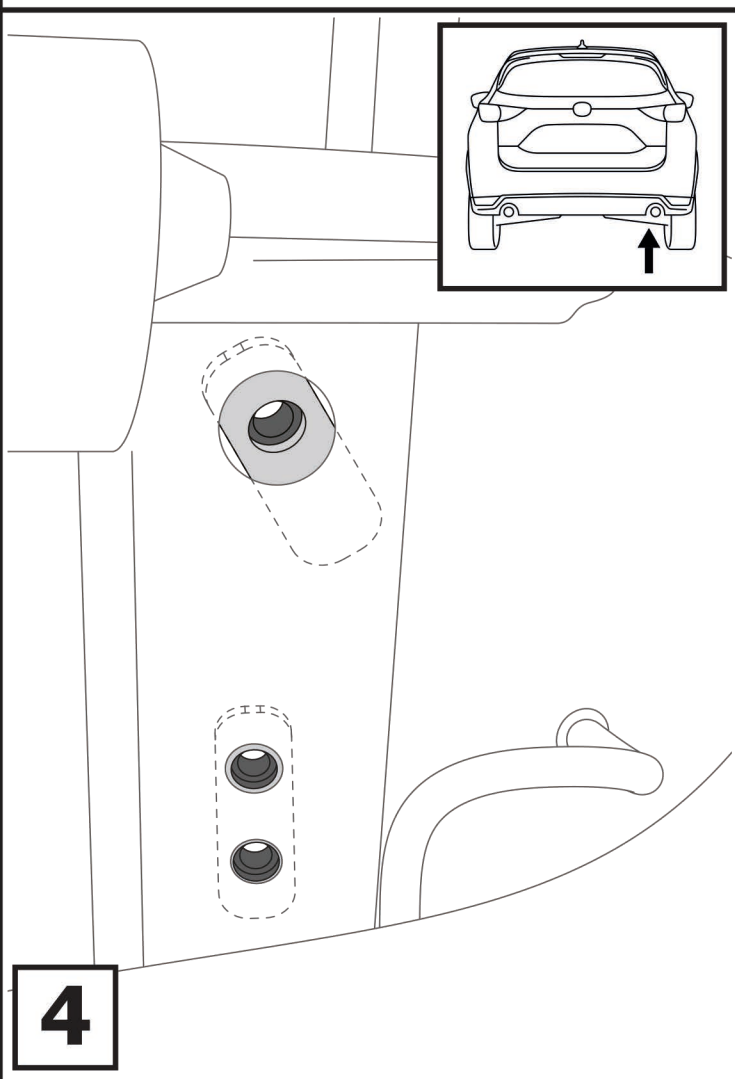
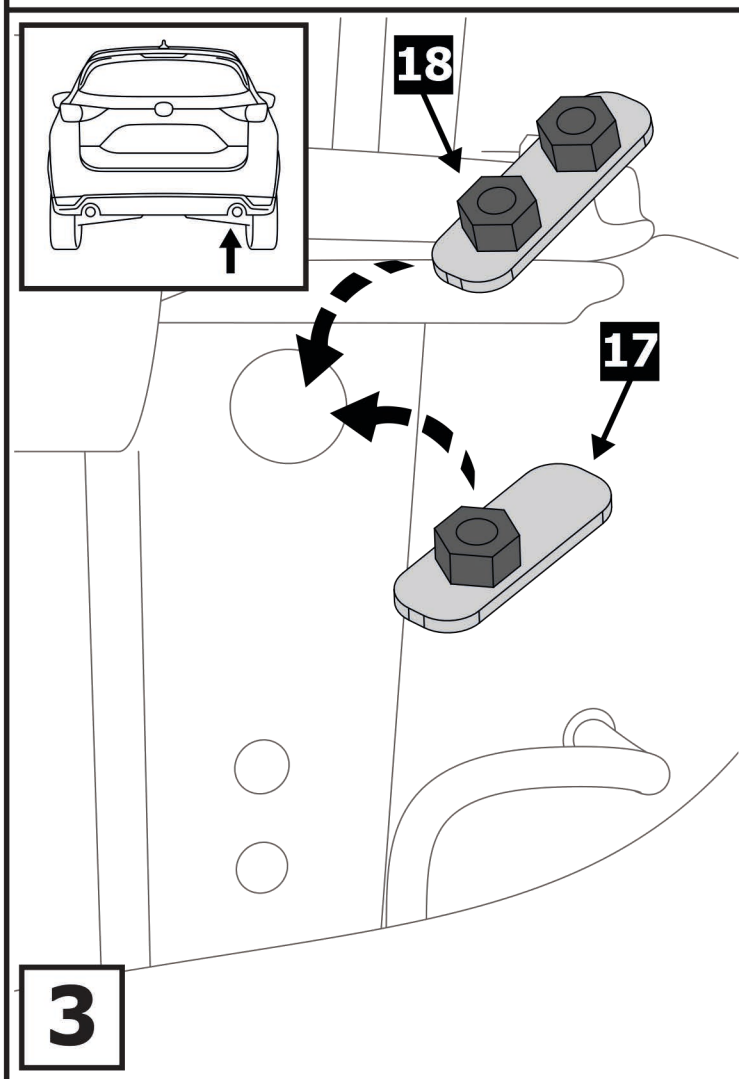
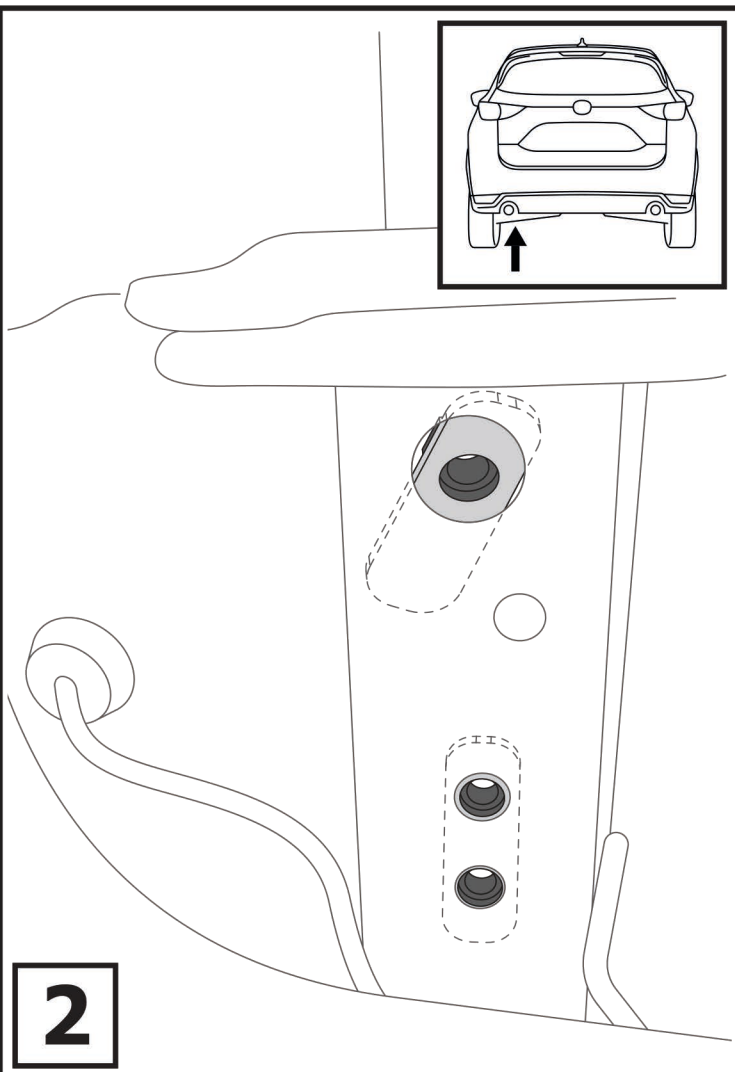
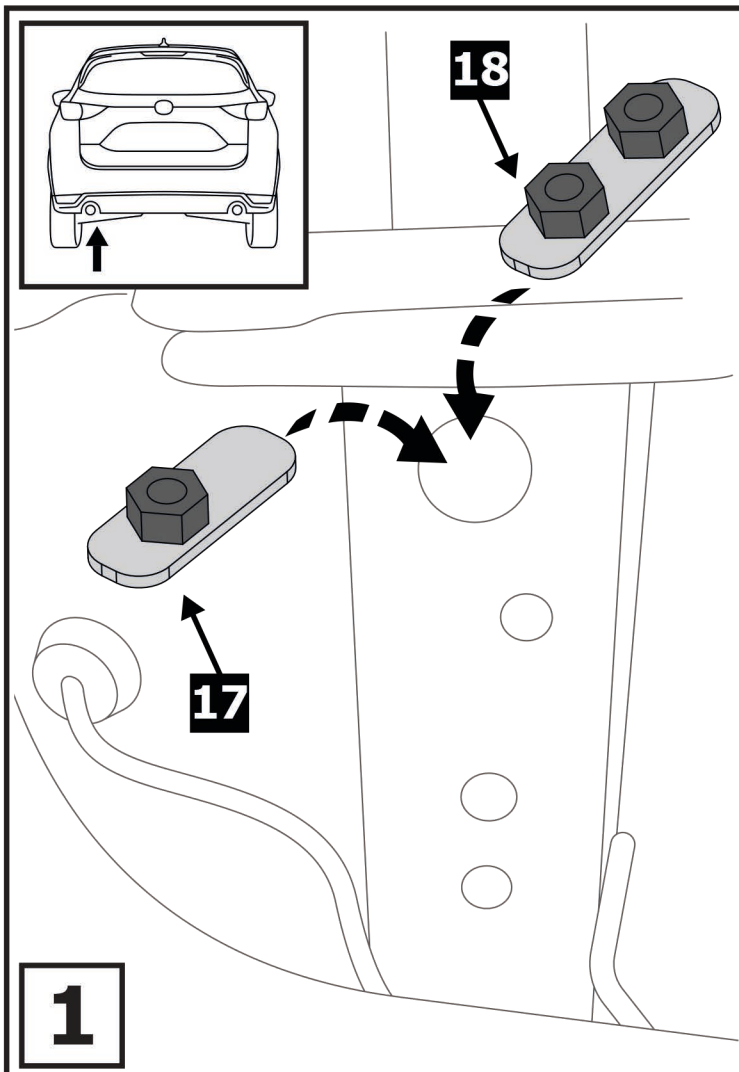

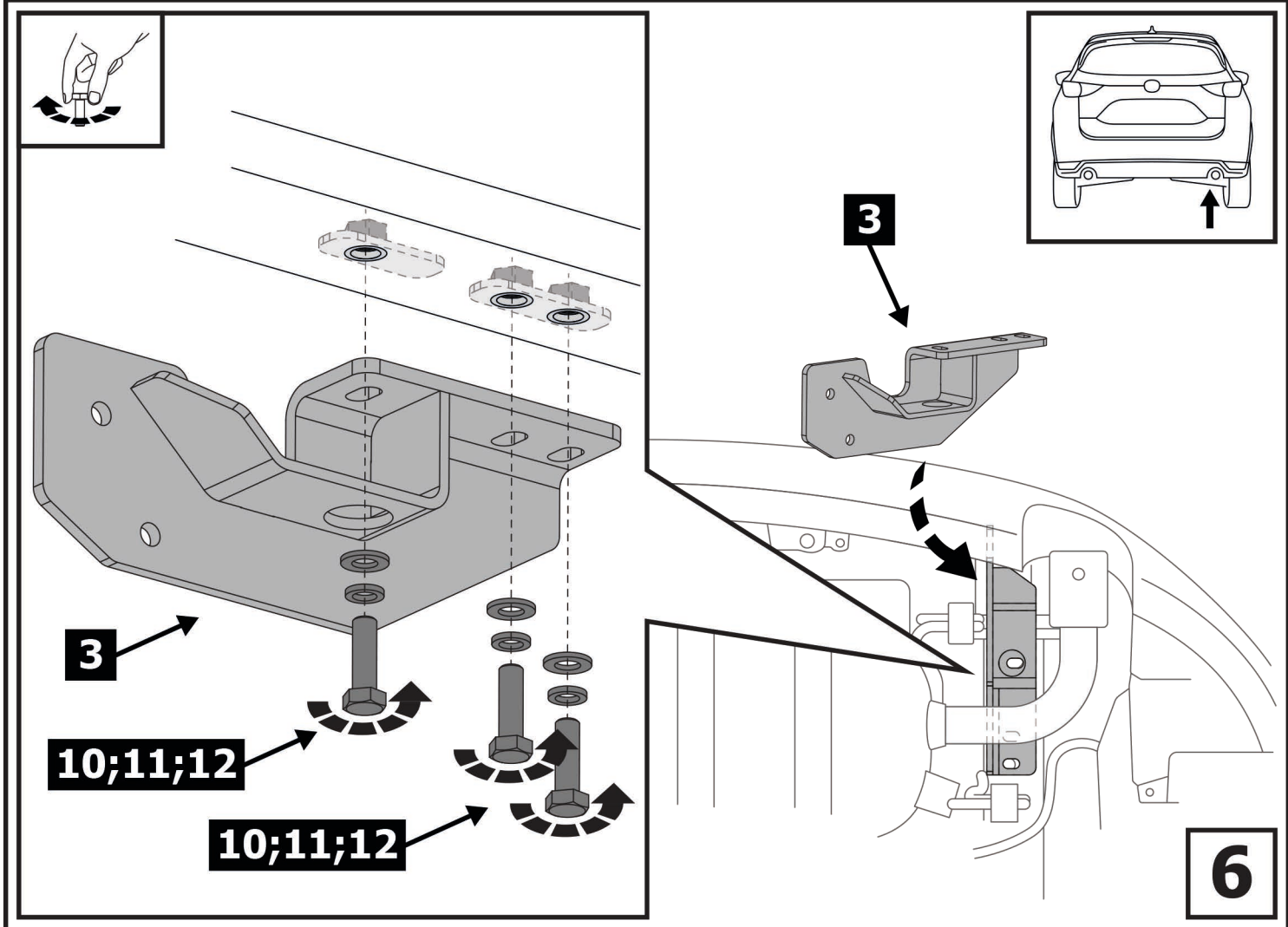
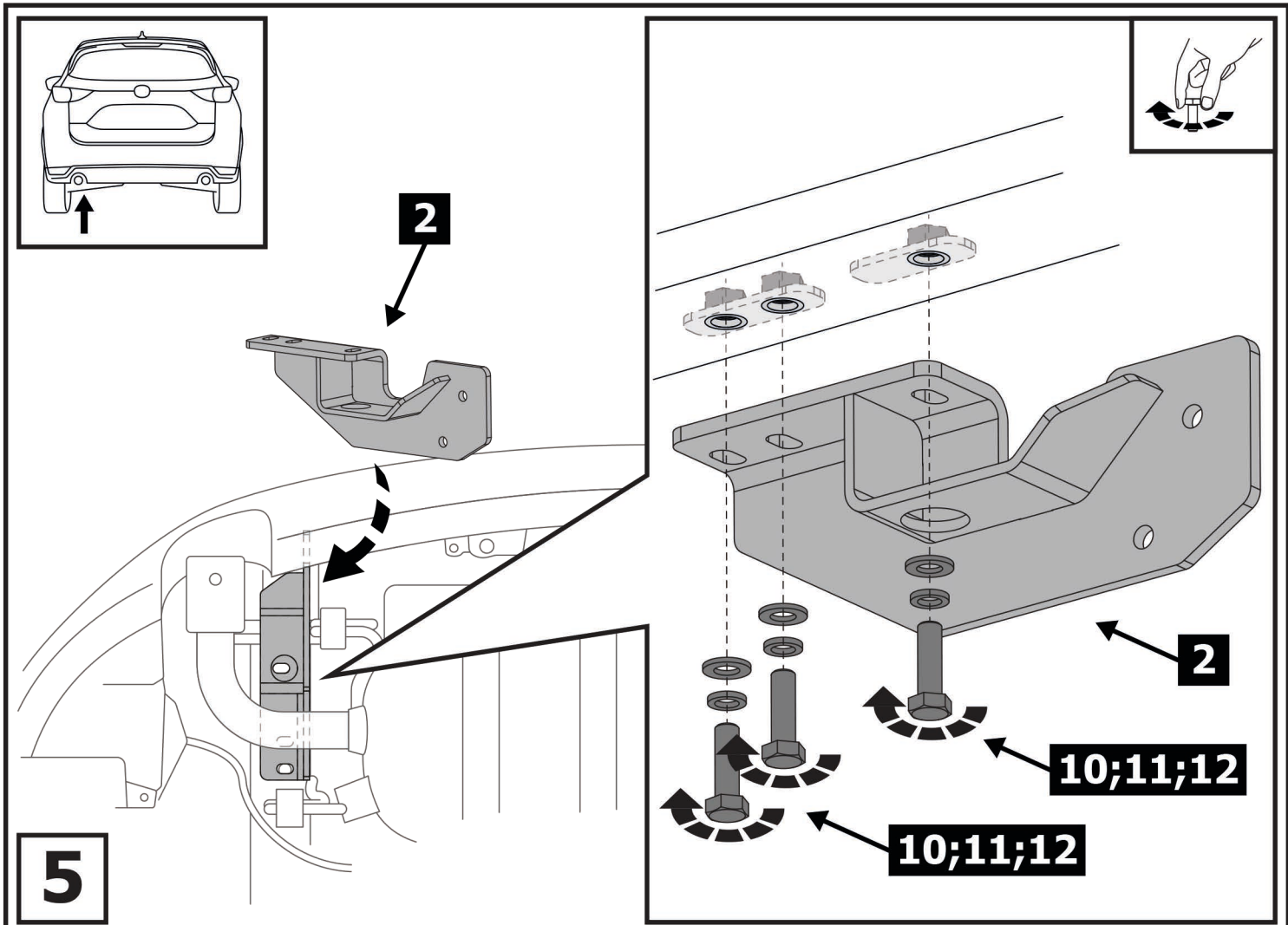

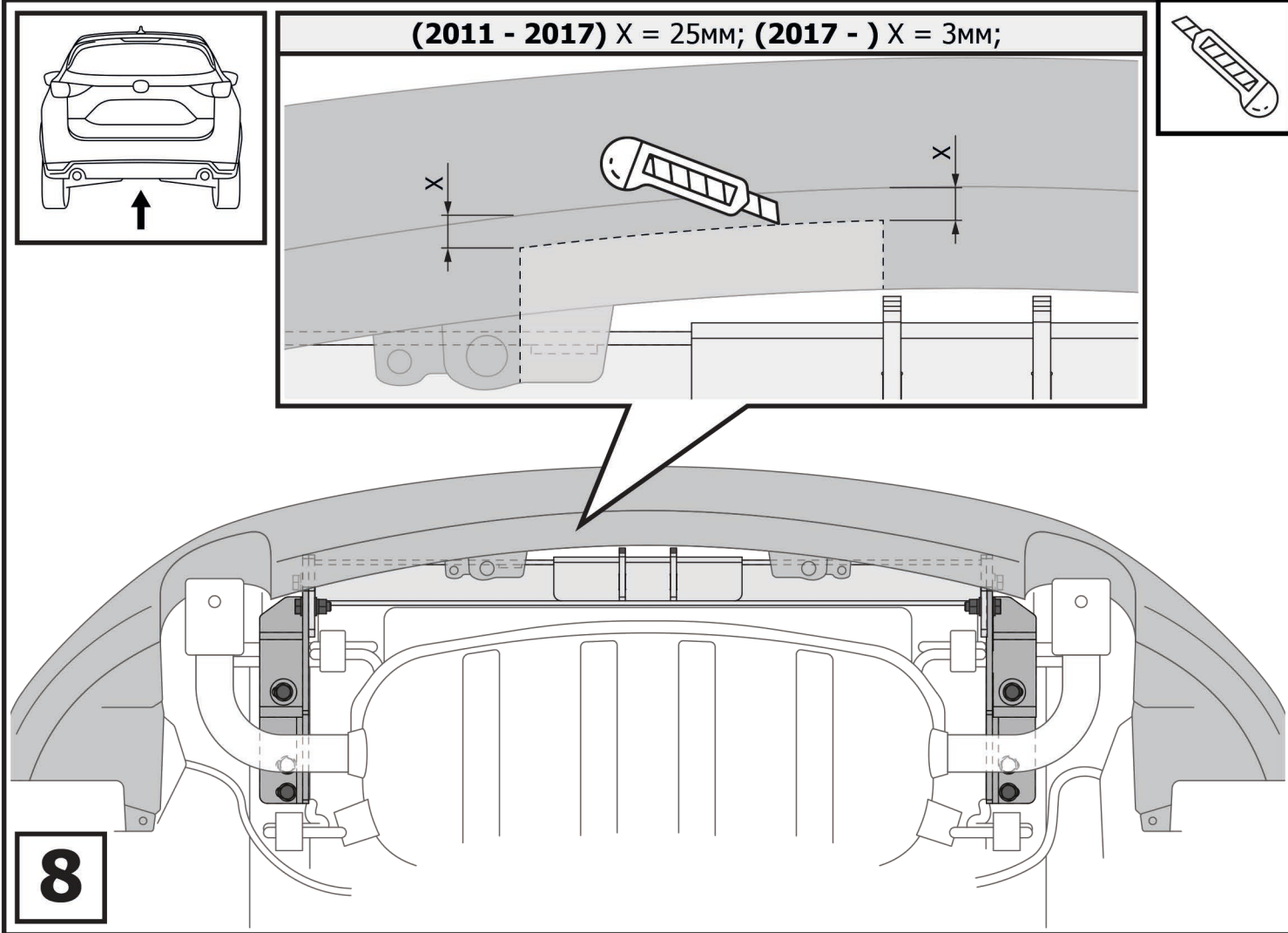
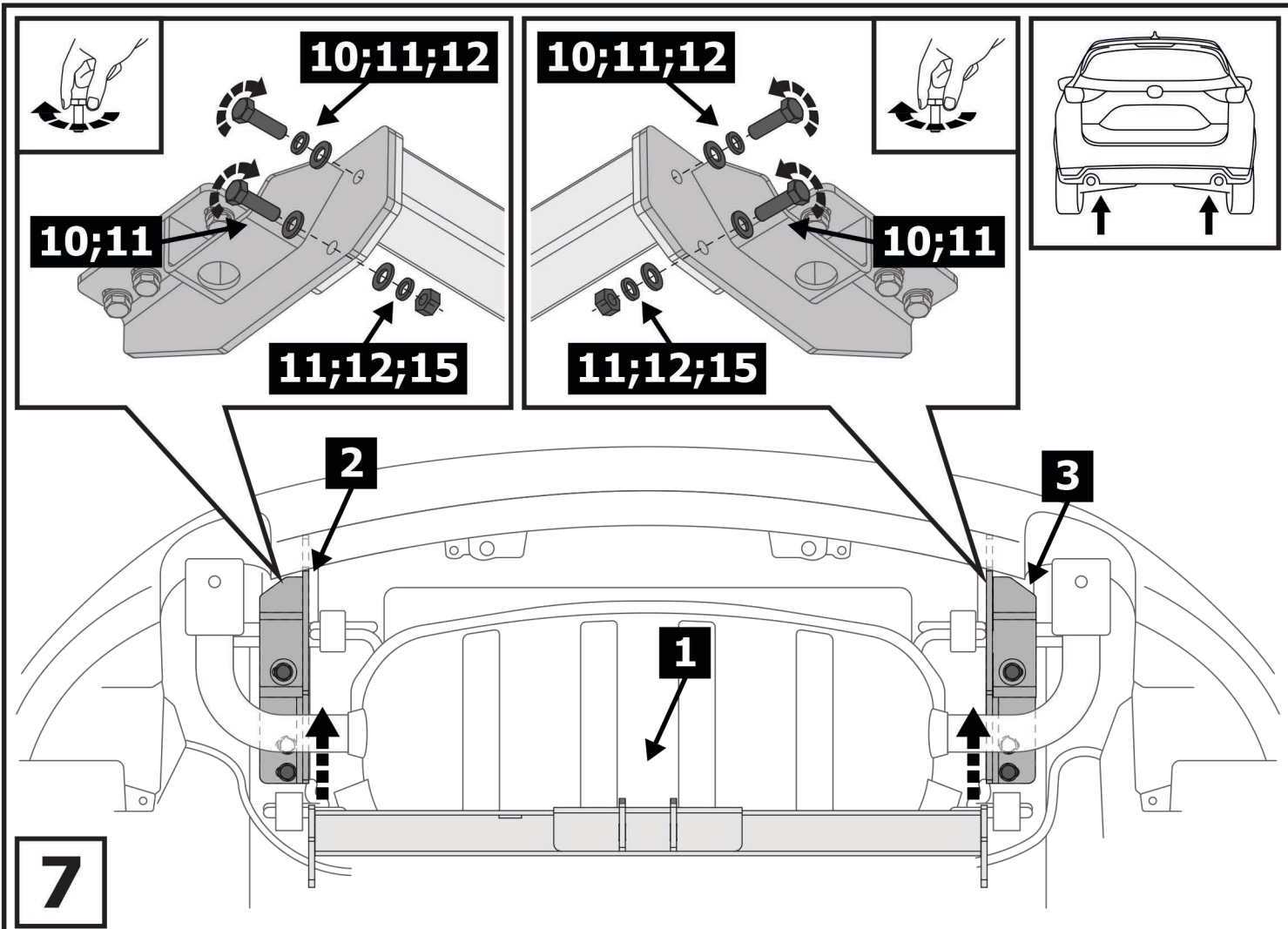

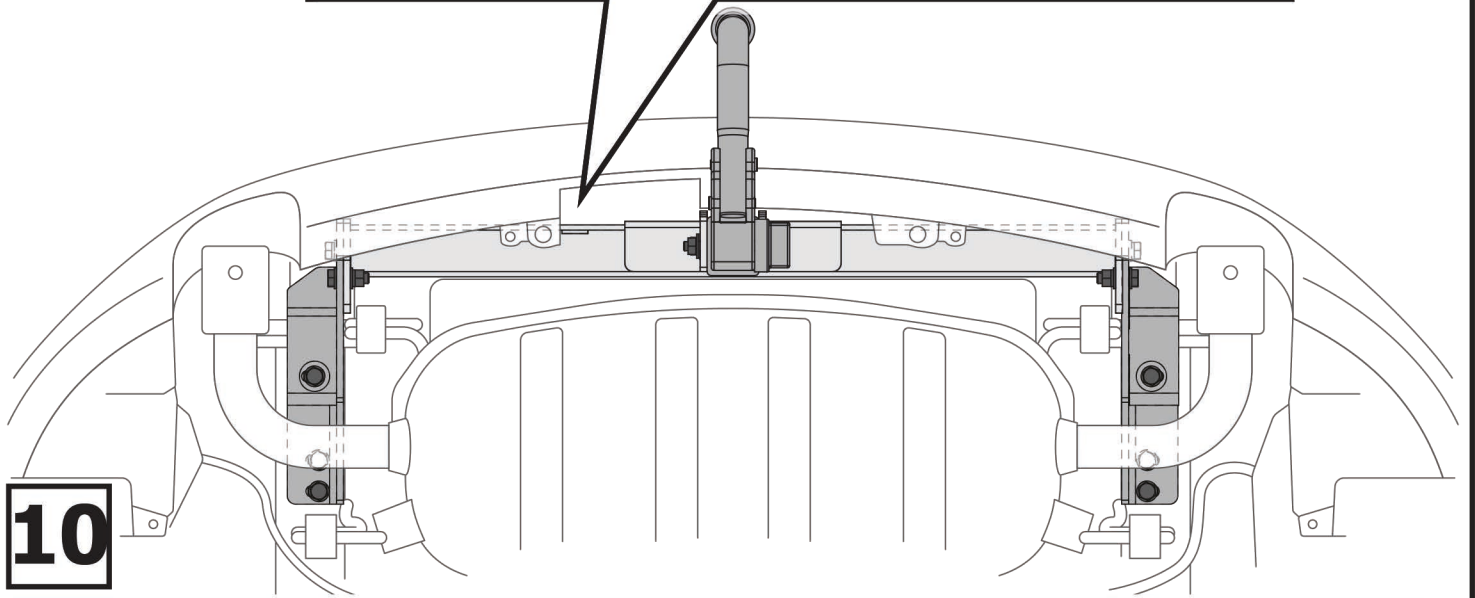
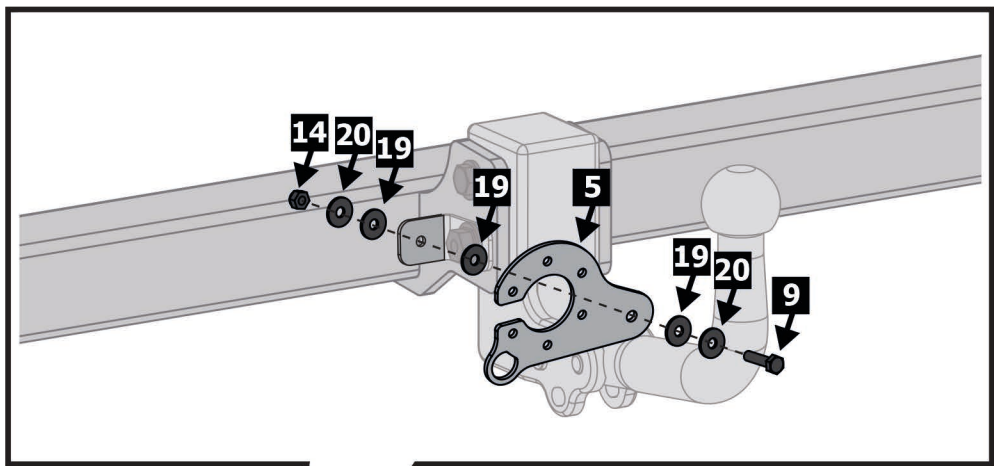
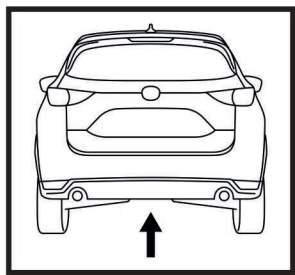
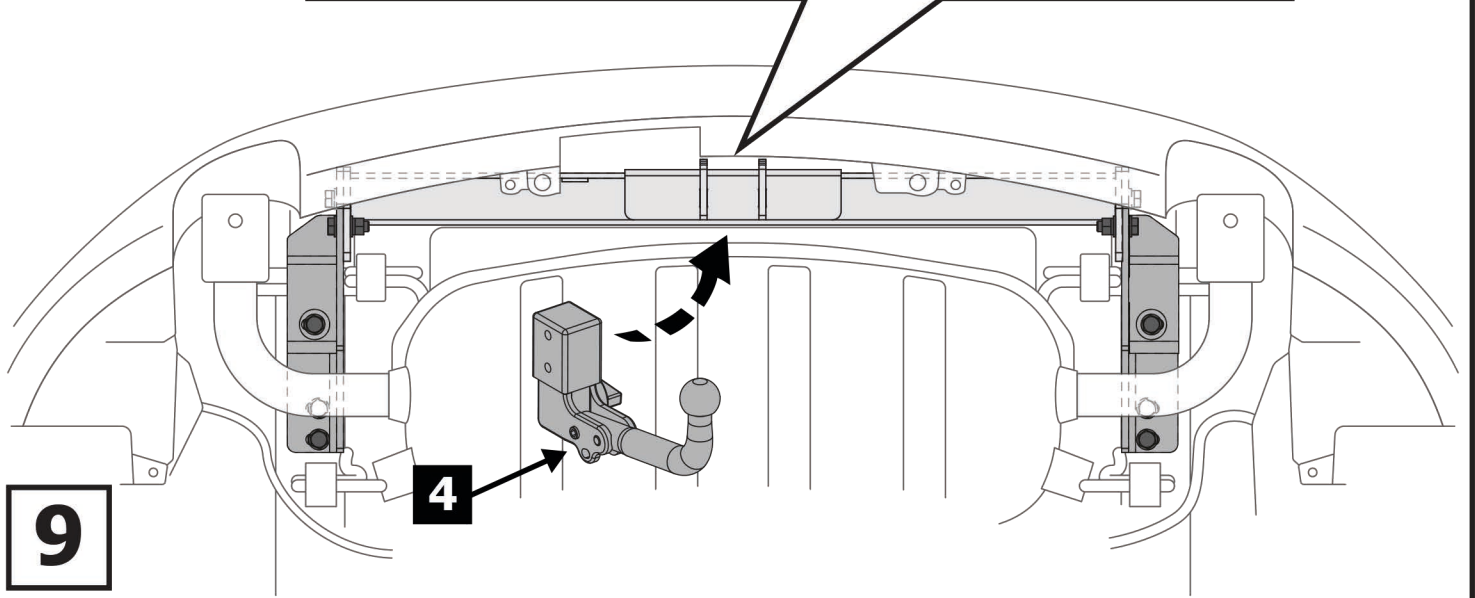
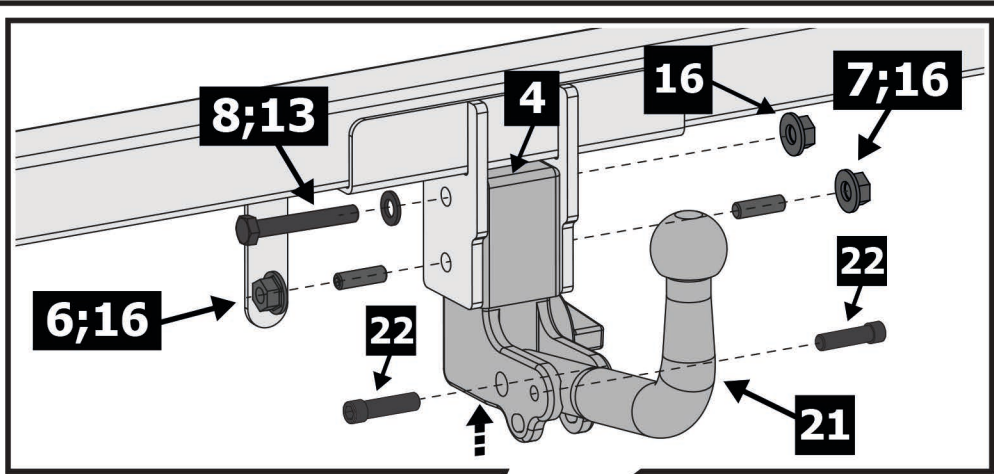
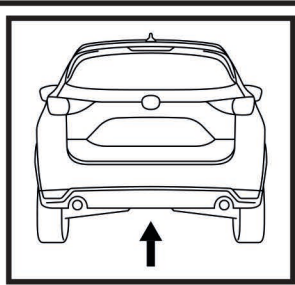

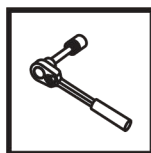
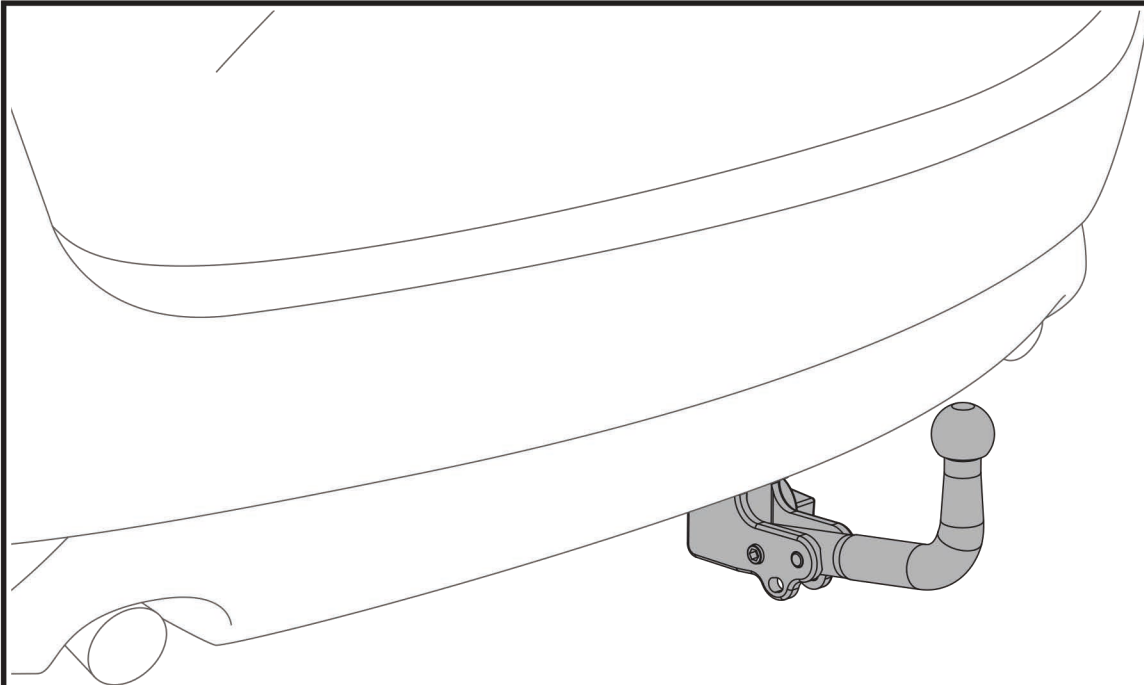

**Затянуть все резьбовые соединения:
M6 = 6 Nm; M12 = 81 Nm**

11